



aquaciat

LD

Cooling capacity : 35 to 270 kW

Heating capacity : 40 to 330 kW



PROPELLER
CONDENSER

Silent operation
Low speed fans
Optimal control
by microprocessor
All year round operation



USE

The new range **AQUACIAT** offers a solution to both heating and cooling applications encountered in the public, tertiary or industrial process fields.

Its remarkable acoustic characteristics, its microprocessor integral control and the large range of versions make this unit suitable to any application.

All the components are mounted on a steel frame with **large dismountable panels to ease maintenance operations.**

This line of products exists in 6 versions :

AQUACIAT LD

COOLING ALONE operation

AQUACIAT LDH

COOLING ALONE operation + hydraulic module

AQUACIAT LDC

COOLING ALONE operation + pumping unit.

AQUACIAT ILD

REVERSIBLE HEATING or COOLING operation

AQUACIAT ILDH

REVERSIBLE HEATING or COOLING operation + hydraulic module

The whole range integrates the last technological innovations and meets following expectations :

- **Silence,**
- **Respect of environment,**
- **Simplicity of installation and reliability.**

QUICK SELECTION

AQUACIAT (LOW NOISE)			100	150	200	250	300	350	400	450	500	600	750	753	900	1000	
Number of circuit(s)			1						2								
Number of compressor(s)			1		2		3			4		5		3		4	
COOLING ALONE LD / LDH / LDC	R407C	Cooling capacity (1)	kW	22.2	34.1	45.5	57.6	67.8	78.1	88.9	96.4	105.5	125.2	153.6	189.8	223.1	244.3
		Compressor power input	kW	10.45	15.35	20.6	25.3	31.1	37.5	42.6	50.5	56.5	69.4	87.8	66.7	83.3	92.85
		Pressure drop	kpa	12.5	24	29	23	31	26	23	22	23.5	26	32	33	32	37
	R22	Cooling capacity (1)	kW	24	36.3	46.9	60.9	71.3	83.5	93.2	102.5	111.2	134.4	164.5	192.5	221.7	253.4
		Compressor power input	kW	9.55	14.45	19.2	23.8	29	35.5	40	47.2	52.8	64.2	81.4	65.5	76.9	88.9
		Pressure drop	kpa	14.5	27	30	26	34	30	25	25	26	29	37	34.6	32.4	31
REVERSIBLE ILD / ILDH	R407C	Cooling capacity (1)	kW	-	-	41.6	52.8	60.8	70.6	82.8	95.3	95.4	114.9	/	177.3	204.7	220.4
		Compressor power input	kW	-	-	20.5	24.7	29.8	36.6	43.1	47.4	55.4	64.6	/	72.5	89.7	99.0
		Pressure drop	kpa	-	-	9.8	15.7	20.6	17.5	20.6	26.5	17.6	27.4	/	27.5	23.6	33.3
		Heating capacity (2)	kW	-	-	46.6	59.1	73.2	82.7	92.4	106.7	114.4	139.5	/	179.5	211.6	230
		Compressor power input	kW	-	-	17.8	23.05	26.4	31.8	34.1	38.9	43.1	52.5	/	64.8	78.6	86.9
		Pressure drop	kpa	-	-	9.8	15.7	20.6	17.5	20.6	26.5	17.6	27.4	/	27.5	23.6	33.3
	R22	Cooling capacity (1)	kW	-	-	45.6	57.1	66.2	76.8	91.2	103.8	108.3	131.1	/	168.2	193.3	213.4
		Compressor power input	kW	-	-	19.2	23.2	28.2	33.9	39.6	44.4	50.2	58.8	/	63.6	78.5	87.5
		Pressure drop	kpa	-	-	13	20	27	22	28	36	25	36	/	28	24.7	29.4
		Heating capacity (1)	kW	-	-	52.4	66	80	88.2	103.9	114.8	125	155.7	/	186.5	216.8	233.5
		Compressor power input	kW	-	-	17.9	22	26.2	31.7	34	37.9	41.9	51.4	/	62.1	74.6	82.9
		Pressure drop	kpa	-	-	13	20	27	22	28	36	25	36	/	28	24.7	29.4

(1) Cooling capacity and power input (without pump) for a +7 °C chilled water outlet and a 35 °C air inlet.

(2) Heating capacity and power input (without pump) for a +45°C hot water outlet with the same water flow as the cooling mode and a +7°C DB RH air inlet.
Exchange fouling factor : 0,000044 m²C/W

DESCRIPTION

AQUACIAT LD

■ Unit conforms to EN 60-204 - EN 378-2 norms and to following directives :

- 98 / 37 CEE

- CEM 89 / 336 CEE modified 92/31 CEE 93/68 CEE

Low voltage 73/23 CEE modified 93/68 CEE

- DESP 97 / 23 CEE -> group 2

■ Scroll hermetic compressor(s)

■ Motor cooled by suction gas

■ Internal motor protection by winding sensor

■ Mounted on resilient mounts

■ Brazed plates evaporator

■ End and internal plates made of AISI 316 stainless steel, with high performance optimized pattern.

■ Thermal insulation

■ Air cooled condenser

■ Copper pipes and mechanically bonded aluminium fins coils

■ Direct drive propeller fan(s) 500 or 750 rpm (standard wiring: 500 rpm)

■ **2 speed motor - IP 55, Class F**

■ Coil protection grille (models 100 to 750

0)

■ Control and safety devices

■ HP safety by manual reset pressostats

■ LP safety :

- by automatic pressostats models ILD 200 to 600

- by pressure pick-up and electronic regulator (other models)

■ Water flow controller mounted

■ Condensing pressure regulation allowing an operation down to - 15°C outside :

- by automatic HP pressostats (models ILD 100 to 600)

- by pressure pick-up and electronic regulator (other models)

■ Evaporator anti-frost protection :

- by trace heating element

- by room heaters models 753 to 1000

■ Control panel

■ Main safety switch with external handle

■ Remote circuit transformer

■ Remote control and power circuits protection

■ Contactors and compressor(s) fan(s) motors protection

■ Wiring numbering

■ **Microprocessor electronic module ensuring the following main functions**

- chilled water temperature control (on evaporator return or departure) or a function of the outside temperature.

- operating parameters control

- faults diagnosis

- automatic equalization of compressors running hours

- remote management and remote survey

- **RS 485** exit for BUS control

- HP and LP pressure pick up for manometers.

AQUACIAT LDH

The basic composition of the **AQUACIAT LDH** water chillers is identical to the AQUACIAT LD

These derived units integrate a **complete hydraulic module** based on a traditional installation :

- 1 buffer tank in black sheet metal, with thermal insulation.
- 1 monocellular centrifugal hydraulic pump (single or double pump).(1)
- 1 expansion vessel
- 1 automatic air vent
- 1 safety valve
- 1 filling hole with valves
- 1 draining hole with valve
- 1 set of manometers
- Contactor(s) and protection device(s) for the hydraulic pump.
- **Hydraulic circuit antifreeze protection through electrical heaters and thermostat (all models) + tank protection by immersion heater (753 to 1000)**
- 1 strainer
- 1 balancing valve (models 100 to 750)

AQUACIAT LDC

The basic composition of the **AQUACIAT LDC** water chillers is identical to the one of the AQUACIAT LD

These derived units integrate the **pumping unit** :

- 1 monocellular centrifugal hydraulic pump (single or double pump).(1)
- 1 expansion vessel
- 1 automatic air vent
- 1 safety valve
- 1 filling hole with valves
- 1 draining hole with valve
- 1 set of manometers
- Contactor(s) and protection device(s) for the hydraulic pump.
- **Hydraulic circuit antifreeze protection**
- 1 strainer
- 1 balancing valve (models 100 to 600)

AQUACIAT serie ILD

The **AQUACIAT ILD** allows, by reversing the thermodynamic cycle, a production of chilled or hot water, depending on the season. Associated with the CIAT terminal units (fan coils, cassettes, air handling units), they offer a maximum comfort and high performances all year around.

AQUACIAT ILDH

The basic composition of **AQUACIAT** units **ILDH** is identical to the one of the AQUACIAT ILD, plus the **hydraulic module**.

IMPORTANT

Each can be equipped with brazed plates **desuperheater(s)** to permanently recover part of the heat for hot water production. This option is particularly suitable for installations operating all year around and **guarantees important energy savings**.

OPTIONS

- Antivibration equipment :
 - hydraulic flexible connections kit
 - High and low pressure gauge panel (ILD - ILDH) 200 to 600
 - Coil protection grille
 - Coil treatment :
 - Polyurethane coated fins
 - Blygold Polual treatment
 - Remote control
 - Dry contacts relay card
 - Variable speed
 - Supply voltage 230 V - 3 ph - 50 Hz
 - Brazed plates desuperheater(s) (Except LDC version)
- (1) Our pumps are designed for operation on a close water loop (low NPSH). For other applications, consult us (open water circuit, important intake height, etc).

AQUACIAT		100		150		200		250		300		350		400		450		500		600		750		753		900		1000	
		LD	LD	LD	ILD	LD	ILD	LD	ILD	LD	ILD	LD	ILD	LD	ILD	LD	ILD	LD	ILD	LD	ILD	LD	ILD	LD	ILD	LD	ILD	LD	ILD
Réf	Operation with R22	●	●	●	●	●	●	●	●	●	●	●	●	●	●	●	●	●	●	●	●	●	●	●	●	●	●	●	
	Operation with R407C (models Z)	●	●	●	●	●	●	●	●	●	●	●	●	●	●	●	●	●	●	●	●	●	●	●	●	●	●	●	
Standard	Coil protection grille	●	●	●	●	●	●	●	●	●	●	●	●	●	●	●	●	●	●	●	●	●	●	●	●	●	●	●	
	Control transformer	●	●	●	-	●	-	●	-	●	-	●	-	●	-	●	-	●	-	●	-	●	-	●	-	●	-	●	
	All year around regulator	●	●	●	●	●	●	●	●	●	●	●	●	●	●	●	●	●	●	●	●	●	●	●	●	●	●	●	
	Anti-frost protection	●	●	●	●	●	●	●	●	●	●	●	●	●	●	●	●	●	●	●	●	●	●	●	●	●	●	●	
	Water flow controller	●	●	●	●	●	●	●	●	●	●	●	●	●	●	●	●	●	●	●	●	●	●	●	●	●	●	●	
	Low speed fans	●	●	●	●	●	●	●	●	●	●	●	●	●	●	●	●	●	●	●	●	●	●	●	●	●	●	●	
	Safety switch	●	●	●	●	●	●	●	●	●	●	●	●	●	●	●	●	●	●	●	●	●	●	●	●	●	●	●	
	Wiring numbering	●	●	●	●	●	●	●	●	●	●	●	●	●	●	●	●	●	●	●	●	●	●	●	●	●	●	●	
	Set of resilient mounts	●	●	●	●	●	●	●	●	●	●	●	●	●	●	●	●	●	●	●	●	●	●	●	●	●	●	●	
	Available options	●	●	●	●	●	●	●	●	●	●	●	●	●	●	●	●	●	●	●	●	●	●	●	●	●	●	●	
Available options	Hydraulic flexible connections kit	▲	▲	▲	▲	▲	▲	▲	▲	▲	▲	▲	▲	▲	▲	▲	▲	▲	▲	▲	▲	▲	▲	▲	▲	▲	▲		
	Pressure gauge panel HP - LP	▲	▲	▲	▲	▲	▲	▲	▲	▲	▲	▲	▲	▲	▲	▲	▲	▲	▲	▲	▲	▲	▲	▲	▲	▲	▲		
	Coil protection treatment	▲	▲	▲	▲	▲	▲	▲	▲	▲	▲	▲	▲	▲	▲	▲	▲	▲	▲	▲	▲	▲	▲	▲	▲	▲	▲		
	Remote control box	▲	▲	▲	▲	▲	▲	▲	▲	▲	▲	▲	▲	▲	▲	▲	▲	▲	▲	▲	▲	▲	▲	▲	▲	▲	▲		
	Potential free contacts relay card	▲	▲	▲	▲	▲	▲	▲	▲	▲	▲	▲	▲	▲	▲	▲	▲	▲	▲	▲	▲	▲	▲	▲	▲	▲	▲		
	Desuperheaters	▲	▲	▲	▲	▲	▲	▲	▲	▲	▲	▲	▲	▲	▲	▲	▲	▲	▲	▲	▲	▲	▲	▲	▲	▲	▲		
	SINGLE pump (version H/C)	●	●	●	●	●	●	●	●	●	●	●	●	●	●	●	●	●	●	●	●	●	●	●	●	●	●		
	DOUBLE pump (version H/C)	▲	▲	▲	▲	▲	▲	▲	▲	▲	▲	▲	▲	▲	▲	▲	▲	▲	▲	▲	▲	▲	▲	▲	▲	▲	▲		
	Variable speed	▲	▲	▲	-	▲	-	▲	-	▲	-	▲	-	▲	-	▲	-	▲	-	▲	-	▲	-	▲	-	▲	-		

● Standard supply ▲ Option - Not available

OPERATING LIMITS

Chilled water production	LD - LDC - LDH
Outside ambient temperature	
°C maxi with full load	
Fans 500 rpm	+40 °C (44 °C -> 753 à 1000)
Fans 750 rpm	+44 °C
Mini °C	-15 °C
Evaporator	
ΔT mini °C	see curves below
ΔT maxi °C	
Hot water production	ILD - ILDH
Outside ambient temperature	
Maxi wet bulb temp °C	+15 °C
Mini wet bulb temp °C	-10 °C
Condenser	
Hot water outlet temperature °C	+50 °C
ΔT mini °C	5 °C
ΔT maxi °C	10 °C

LD - LDC - LDH 100Z to 1000Z

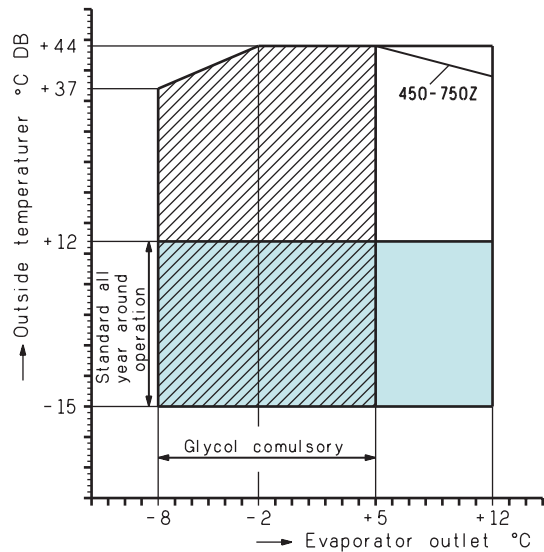

Evaporator

The curves below represent the minimum and maximum temperature differences admissible on the chilled or glycolated water, as a function of the outlet temperature.

LD - LDC - LDH 100 to 1000

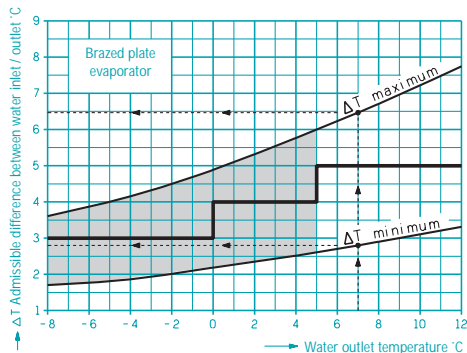

— Performance tables calculations ΔT
 shaded area glycol water

Example : for a water outlet : + 7 °C
 ΔT minimum : 2,8 °C / water temp : 9,8 / 7 °C
 ΔT maximum : 6,5 °C / water temp : 13,5 / 7 °C
 For temperature differences not included between the two curves, consult us.

ILD - ILDH 200 to 1000

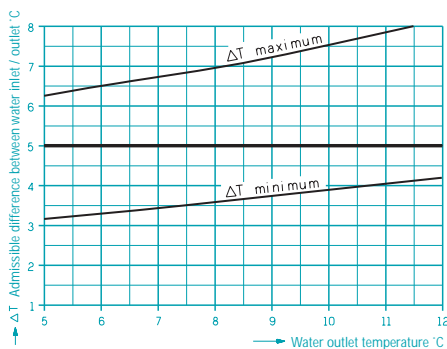

— Performance tables calculations ΔT

ILD - ILDH 100Z to 1000Z

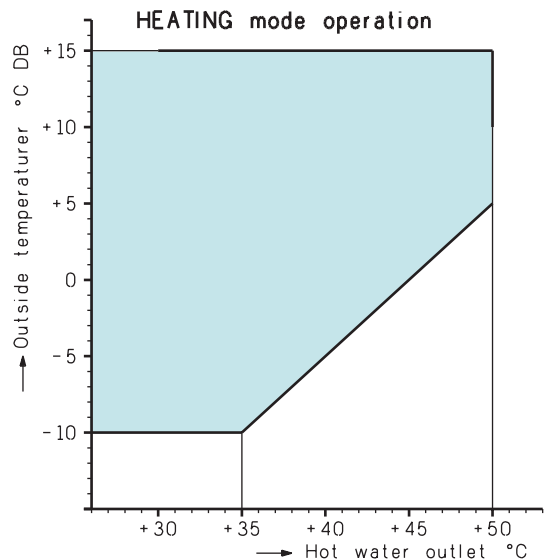
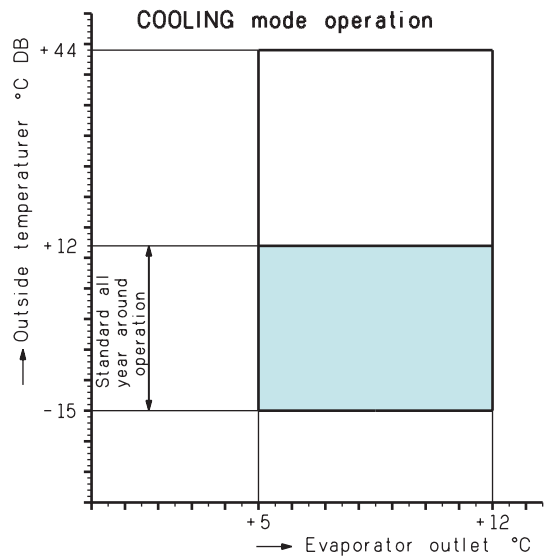

GLYCOL WATER COEFFICIENT

- 30 % concentration by glycol weight
- Freezing point of the solution : - 17.5 °C

CORRECTION		POSITIVE CONDITIONS		NEGATIVE CONDITIONS	
		K	Calculation mode	K	Calculation mode
Evaporator	Cooling capacity	0,98	$P_{fc} = P_f \times 0,98$	1,00	See selection table
	Chilled water flow	1,05	$Q_c = P_{fc} \times 0,86 \times 1,05$	1,10	$Q_c = P_{fc} \times 0,86 \times 1,10$
	Water pressure	1,15	$\Delta P_c = \Delta P \times 1,15$	1,30	$\Delta P_c = \Delta P \times 1,30$
	Average temp.	12 / 7 ° C		See table	
Condenser	Cooling capacity	0,97	$P_{fc} = P_f \times 0,97$		
	Chilled water flow	1,05	$Q_c = (P_{fc} + P_a) \times 0,86 \times 1,10$		
	Water pressure	1,10	$\Delta P_c = \Delta P \times 1,10$		
	Average temp.	35 / 40 ° C			

K : Correction coefficient

Values written in the brochure :

P_f : cooling capacity as per selection table

P_a : compressors power input as per selection tables

ΔP : water pressure drop as per curves, for the corresponding corrected flow value (Q_c)

Values corrected as per above calculations :

P_{fc} : corrected cooling capacity

Q_c : corrected flow, chilled or hot water

ΔP_c : corrected water pressure drop, evaporator or condenser

UNITS CONVERSION FORMULA

USRT	kW x 0,2846
Btu/h	kW x 3414
kcal/h	kW x 860
Frig/h	kcal/h
Cheval vapeur (CH)	kW x 1,36
Horsepower (HP)	kW x 1,341
kPa	bar x 100
bar	mCE x 0,0981
kg/cm ²	bar x 1,0197
Livre/Pouce ² (lbf/in ²)	bar x 14,504
Pouce (in)	mm x 0,0394
Pied (ft)	mm x 0,0032808
Livre (lb)	kg x 2,205
Pied ³ /mn (cfm)	m ³ /h x 0,5885
Gallons US	m ³ x 264,2
Gallons UK	m ³ x 220
Degré Fahrenheit (°F)	(°C x 9/5) + 32

PROPELLER
CONDENSER

MINIMUM WATER VOLUME

- LD - LDC - LDH / ILD - ILDH

The Connect control is equipped with an anticipation logic allowing high flexibility in adjusting the set points according to the parameters drifting, in particular for low water volume hydraulic installations.

An adapted management of the compressors operating periods avoids therefore the start of anti-short cycle functions, and in most cases, the requirement of a buffer tank.

Models LD - ILD - LDC	100	150	200	250	300	350	400	450	500	600	750	753	900	1000
Minimum volume Of installation	112	181	110	112	174	121	174	167	106	164	161	327	257	322

Remark :

Industrial processes which require high stability of water temperatures or installations with high thermal load variation can privilege the use of LDH-ILDH models equipped with a buffer tank.

COOLING CAPACITY



STANDARD version



PROPELLER
CONDENSER

AQUACIAT LD - LDC - LDH		Evaporator water outlet temperature in °C	INLET AIR TEMPERATURE AT THE CONDENSER °C													
			28		32		36		40		44					
			Pf kW	Pa kW	Pf kW	Pa kW	Pf kW	Pa kW	Pf kW	Pa kW	Pf kW	Pa kW				
100Z	Fans 750 rpm	Glycol water	-8	13,4	6,9	12,6	7,5	11,9	8,2							
			-4	15,9	7,1	15,0	7,8	14,2	8,5	13,4	9,3					
			2	20,3	7,5	19,3	8,2	18,3	8,9	17,2	9,8	16,0	10,7			
		Pure water	5	23,9	7,8	22,6	8,5	21,4	9,3	20,2	10,2	18,8	11,1			
			7	25,5	7,9	24,3	8,6	23,0	9,4	21,8	10,3	20,2	11,3			
			12	30,5	8,2	28,9	9,0	27,4	9,8	25,8	10,7	24,2	11,7			
	150Z	Fans 750 rpm	Glycol water	-8	20,7	10,0	19,7	10,9	18,7	11,9						
				-4	24,9	10,4	23,6	11,3	22,6	12,3	21,4	13,4				
				2	31,8	11,0	30,4	11,9	28,9	12,9	27,2	14,1	25,9	15,3		
			Pure water	5	36,6	11,4	35,3	12,4	33,6	13,4	31,9	14,6	30,1	15,8		
				7	39,6	11,7	37,9	12,6	36,2	13,7	34,1	14,8	32,3	16,1		
				12	46,7	12,3	44,8	13,3	42,6	14,4	40,4	15,6	38,1	16,8		
200Z	Fans 750 rpm	Glycol water	-8	26,8	13,6	25,7	14,8	24,3	16,2							
			-4	32,2	14,0	30,9	15,3	29,0	16,7	27,5	18,3					
			2	41,7	14,8	39,8	16,1	37,7	17,5	35,6	19,1	33,1	20,9			
		Pure water	5	48,2	15,3	46,3	16,7	44,0	18,2	41,3	19,8	39,0	21,6			
			7	52,1	15,6	49,5	17,0	47,1	18,5	44,6	20,1	41,8	21,9			
			12	61,5	16,4	58,7	17,8	55,9	19,4	52,4	21,0	49,7	22,9			
250Z	Fans 750 rpm	Glycol water	-8	34,0	16,8	32,8	18,3	30,8	19,9							
			-4	40,8	17,3	39,3	18,9	36,9	20,5	35,2	22,4					
			2	52,2	18,2	50,4	19,8	47,9	21,6	45,3	23,5	42,6	25,6			
		Pure water	5	60,6	18,9	58,6	20,6	55,8	22,3	52,3	24,3	49,7	26,4			
			7	65,8	19,3	62,7	20,9	60,0	22,8	56,8	24,7	53,1	26,8			
			12	78,3	20,3	74,3	22,0	70,7	23,8	67,0	25,9	63,3	28,1			
300Z	Fans 750 rpm	Glycol water	-8	41,2	20,2	39,4	21,9	37,4	23,9							
			-4	49,1	20,9	46,9	22,8	44,5	24,7	42,6	27,0					
			2	63,3	22,2	60,0	24,0	57,5	26,1	54,5	28,4	51,4	30,8			
		Pure water	5	72,9	23,0	70,3	25,0	67,0	27,1	63,5	29,4	59,8	31,9			
			7	78,4	23,5	75,0	25,4	71,5	27,8	68,2	30,0	64,1	32,4			
			12	93,0	24,8	88,9	26,9	84,7	29,1	80,2	31,4	75,8	34,0			
350Z	Fans 750 rpm	Glycol water	-8	47,2	23,9	45,2	26,1	42,7	28,4							
			-4	56,5	24,7	54,2	27,0	51,5	29,4	48,3	32,0					
			2	71,9	26,2	69,7	28,6	65,8	31,0	62,4	33,8	58,6	36,7			
		Pure water	5	84,2	27,4	81,0	29,8	76,7	32,3	72,1	35,0	68,3	38,1			
			7	91,1	28,1	86,3	30,3	82,0	32,9	77,8	35,8	73,1	38,8			
			12	105,7	29,8	101,8	32,1	97,2	34,8	92,2	37,7	87,0	40,8			
400Z	Fans 750 rpm	Glycol water	-8	54,5	27,1	52,2	29,5	49,4	32,1							
			-4	64,7	28,0	62,2	30,5	59,2	33,2	56,2	36,2					
			2	82,2	29,6	79,0	32,2	75,2	35,1	71,6	38,1	67,5	41,4			
		Pure water	5	96,6	30,9	92,6	33,6	88,2	36,5	83,4	39,6	78,5	42,9			
			7	103,9	31,6	99,4	34,3	94,5	37,3	89,4	40,3	84,5	43,7			
			12	121,6	33,4	116,8	36,2	111,5	39,2	105,8	42,5	99,8	46,0			
450Z	Fans 750 rpm	Glycol water	-8	60,7	31,8	58,1	34,6	54,4	37,6							
			-4	72,6	33,1	69,1	36,0	65,3	39,1	61,5	42,4					
			2	90,7	35,2	87,0	38,2	82,8	41,6	78,3	45,0	73,3	48,7			
		Pure water	5	106,0	37,1	101,0	40,2	96,2	43,5	90,8	47,1	85,6	50,9			
			7	113,5	38,0	108,3	41,2	102,9	44,5	97,3	48,1	91,5	52,0			
			12	133,0	40,4	127,1	43,8	121,0	47,3	114,3	51,0					

Pf : Cooling capacity valid for a ΔT according to operating limits.
 Inlet / outlet difference, as per curve page 4
 Pa : Compressor power input

Zone when glycol water must be used.
 Calculation fouling 0,00005 m² °C/W

COOLING CAPACITY



LOW NOISE version

PROPELLER
CONDENSER

AQUACIAT LD - LDC - LDH		Evaporator water outlet temperature in °C	INLET AIR TEMPERATURE AT THE CONDENSER °C									
			28		32		36		40			
			Pf kW	Pa kW	Pf kW	Pa kW	Pf kW	Pa kW	Pf kW	Pa kW		
100Z	Fans 500 rpm	Glycol water	-8	13,1	7,2	12,3	7,8					
			-4	15,4	7,5	14,6	8,1	13,7	8,9			
			2	19,6	7,9	18,6	8,7	17,6	9,5	16,4	10,4	
		Pure water	5	23,0	8,3	21,7	9,1	20,5	9,9	19,1	10,8	
			7	24,4	8,5	23,2	9,3	21,9	10,1	20,5	11,1	
			12	28,9	9,0	27,6	9,8	25,9	10,7	24,3	11,6	
	150Z	Fans 500 rpm	Glycol water	-8	20,1	10,6	19,1	11,5				
				-4	24,0	11,1	22,9	12,1	21,5	13,1	20,5	14,2
				2	30,3	11,9	28,9	12,9	27,4	14,0	26,0	15,2
			Pure water	5	35,0	12,6	33,1	13,6	31,7	14,7	30,0	15,9
				7	37,1	12,9	35,4	13,9	33,7	15,1	31,8	16,3
				12	43,6	13,8	41,6	14,9	39,3	16,2	37,5	17,4
200Z	Fans 500 rpm	Glycol water	-8	26,1	14,1	25,1	15,4	23,6	16,9			
			-4	31,6	14,7	30,0	16,0	28,4	17,5	26,6	19,1	
			2	40,0	15,6	38,0	17,0	36,2	18,6	33,8	20,3	
		Pure water	5	46,4	16,4	44,5	17,9	42,0	19,5	39,6	21,2	
			7	49,9	16,8	47,4	18,3	44,9	19,9	42,2	21,6	
			12	58,7	17,9	55,8	19,4	52,8	21,1	49,8	22,9	
250Z	Fans 500 rpm	Glycol water	-8	33,3	17,5	32,0	19,2	30,2	20,9			
			-4	40,0	18,3	38,0	19,9	35,7	21,7	33,5	23,6	
			2	50,3	19,5	48,4	21,3	45,8	23,1	43,3	25,1	
		Pure water	5	58,5	20,5	55,9	22,3	52,8	24,1	50,1	26,2	
			7	62,5	21,0	59,9	22,8	56,8	24,7	53,5	26,8	
			12	73,6	22,4	70,5	24,3	66,5	26,2	62,8	28,4	
300Z	Fans 500 rpm	Glycol water	-8	40,1	21,3	38,1	23,1					
			-4	47,8	22,4	45,1	24,3	43,2	26,5			
			2	60,4	24,1	57,5	26,2	54,2	28,3	51,5	30,7	
		Pure water	5	69,1	25,4	66,3	27,6	62,9	29,8	59,4	32,2	
			7	74,4	26,2	70,9	28,3	66,8	30,5	63,2	32,9	
			12	86,9	28,1	82,5	30,2	78,3	32,6	74,0	35,1	
350Z	Fans 500 rpm	Glycol water	-8	45,8	25,2	43,8	27,5					
			-4	55,1	26,5	52,0	28,8	49,2	31,3	46,4	36,0	
			2	69,6	28,6	66,2	31,0	62,6	33,7	59,0	36,5	
		Pure water	5	79,6	30,1	75,9	32,6	72,0	35,3	67,8	38,3	
			7	85,4	31,0	81,2	33,7	77,1	36,3	72,5	39,3	
			12	99,0	33,2	94,3	36,1	89,7	38,8			
400Z	Fans 500 rpm	Glycol water	-8	52,9	28,9	50,6	31,4					
			-4	62,6	30,2	59,4	32,8	56,4	35,7			
			2	79,0	32,7	75,3	35,4	71,4	38,4	67,6	41,6	
		Pure water	5	91,0	34,6	86,7	37,4	82,1	40,4	77,4	43,7	
			7	97,3	35,6	92,6	38,5	87,7	41,6	82,7	44,9	
			12	113,0	38,4	107,8	41,4	102,2	44,6			
450Z	Fans 500 rpm	Glycol water	-8	58,1	33,9	55,4	36,8					
			-4	68,9	35,7	65,6	38,7	61,9	41,9	58,4	45,5	
			2	85,5	38,6	81,5	41,9	77,6	45,4	73,2	49,1	
		Pure water	5	99,6	41,4	94,2	44,6	89,0	48,1	84,2	51,9	
			7	105,6	42,8	100,4	46,0	95,1	49,6			
			12	122,7	46,2	116,4	49,7	110,2	53,3			

Pf : Cooling capacity valid for a ΔT according to operating limits.
 Inlet / outlet difference, as per curve page 4
 Pa : Compressor power input

Zone when glycol water must be used.
 Calculation fouling 0,00005 m² °C/W

WATER PRESSURE DROP

AQUACIAT LDC LDH 100 to 600

Evaporator and hydraulic circuit

PROPELLER
CONDENSER

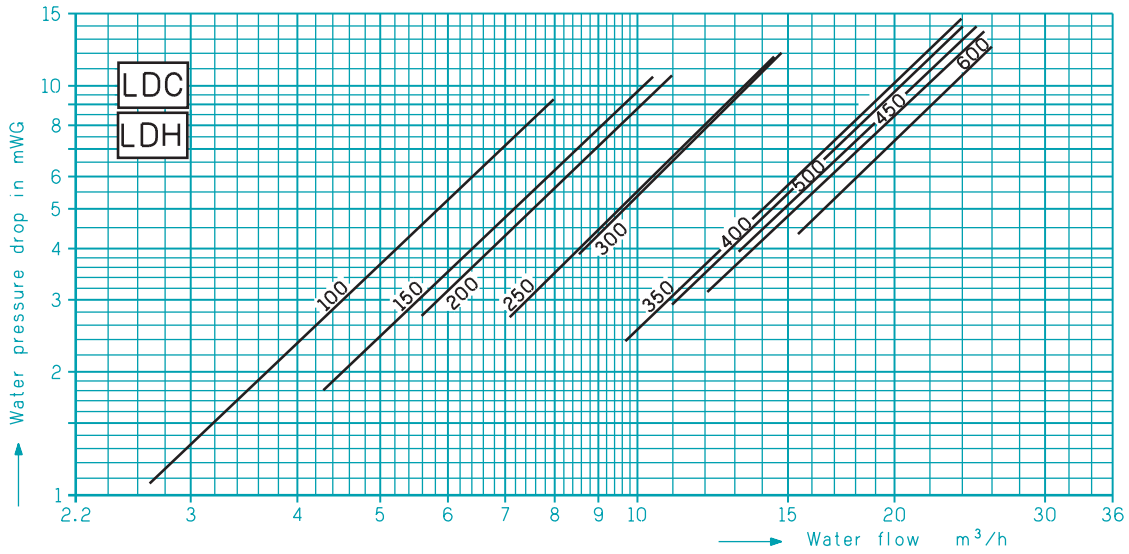

Single pumps or 2 single pumps in parallel

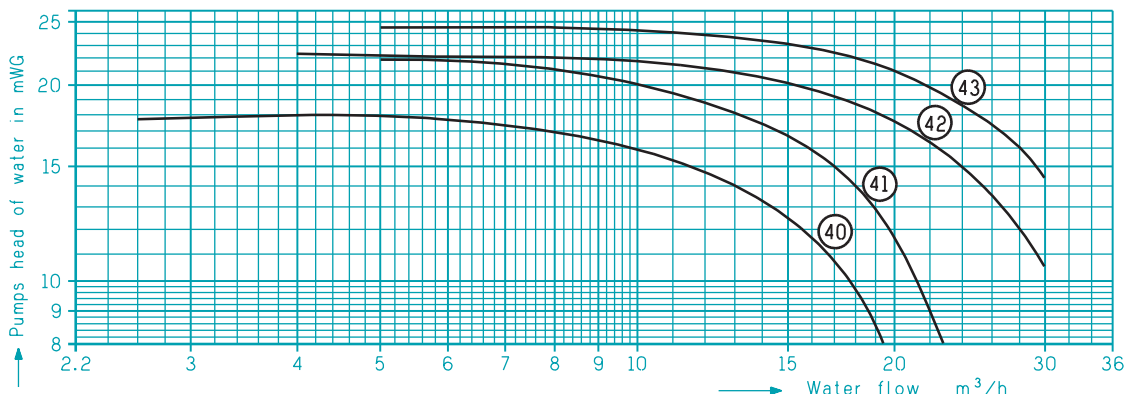



AQUACIAT		100	150	200	250	300	350	400	450	500	600	750	753	900	1000	
Compressor	Type	SCROLL hermetic														
	Number	1	2			3			4	5	3	4				
	Rotation speed rpm	2900														
	LD - LDC LDH Charge R22/R407C	54	9.2	11.5	14.0	19.0	19.0	21	23.5	26.0	30.0	40.0	43	44	53	
kg			12.6	16	20	20	26,5	28	32.5	37,6		57.5	62	62		
Capacity control %		100 - 0	100-50-0	100-40-0	100-50-0	100-70-30-0	100-63-37-0	100-66-33-0	100-70-40-20-0	100-75-50-25-0	100-80-60-20-0	100-66-33-0	100-78-50-28-0	100-75-50-25-0		
Régulateur	LD - LDC - LDH	CONNECT														
	ILD - ILDH		MRS 4.2 A				MRS 3.4 A				CONNECT					
Evaporator	LD - LDC LDH	Braze plates														
	Type															
	Number	1						2								
	Water contents l	1,9	2,85	3,39	5,65	7,5	7,95	9,20	9,70	11,4	16,5	15,8				
	ILD - ILDH	Shell and tube														
	Type											Braze plates				
Number	1										2					
Water contents l	19				25	33		41		16,5	15,8					
Type of Fans	Propeller, diameter 760						Propeller, diameter 900				Propeller, diameter 800					
Number of Fans	LD LDC LDH	1			2				3			4				
	ILD - ILDH					2				3		4				
Air cooled condenser	Unitary power kW	0,55						0,90								
	500 rpm LOW NOISE	LD - LDC LDH	9360	8200	18540	17340	16100	19240	18750	20520	20080	28770	28050	57110	56700	
		ILD - ILDH			18540	17340	16100	20920	21780	20870	22440	29530		57110	56700	
	Unitary power kW	0,9						1,30								
	750 rpm STANDARD	LD - LDC LDH	15050	13480	29840	28200	26520	31380	31100	33080	32800	46980	46575	68420	66900	
		ILD - ILDH			29840	28200	26520	33720	34780	33650	35620	48200		68420	66900	
LD LD LD LD LD	Auxiliary capacity l	160			320								500			
	Expansion vessel Capacity l	18			LDC 18 / LDH 24				24				35			
	Expansion vessel Pressure bar	1,5														
○ Max. installation capacity in liters (2)																
Hydraulic module (1)	Pure water	○ water max 36 °C (3)	1700			2150			2700				5760			
		○ water max 46 °C (3)	900			1100			1900				3523			
	Glycol water	○ water max 36 °C (3)	1200			1500			2250				4230			
		- water max 46 °C (3)	550			650			1400				2642			
	Pump standard	ILDH - ILDH - LDC	N°/kW			40/0.75			41/1.15			According to installation requirement (selection in chart)				

(1) LDH - LDC - ILDH only

(2) Capacity of the installation as a function of the expansion vessel mounted on the unit.

The auxiliary tank is already taken into account. In the case where the installation capacity is higher, an expansion vessel must be added on the installation corresponding to the surplus capacity.

(3) The water temperatures mentioned are the temperatures which can be reached when the unit is stopped.

ELECTRICAL CHARACTERISTICS

PROPELLER
CONDENSER

AQUACIAT		100	150	200	250	300	350	400	450	500	600	750	753	900	1000
		COMPRESSOR(S)													
Max. nominal current in A	* 230 V	35,1	50,9	70,2	86,0	101,8	121,1	136,9	152,7	172,0	203,6	254,5	-	-	-
	400 V	19,8	29,2	39,6	49,0	58,4	68,8	78,2	87,6	98,0	116,8	146,0	142,5	172	190
		FAN MOTORS 500 rpm													
Max. nominal current in A	* 230 V	2		4 (2 x 2)			7 (2 x 3,5)			10,5 (3 x 3,5)		13,2 (3 x 3,3)			
	400 V	1,15		2,3 (2 x 1,15)			4 (2 x 2)			6 (3 x 2)		7,6 (4 x 1,9)			
		FAN MOTORS 750 rpm													
Max. nominal current in A	* 230 V	3,65		7,3 (2 x 3,65)			14 (2 x 7)			21 (3 x 7)		26,4 (4 x 6,6)			
	400 V	2,1		4,2 (2 x 2,1)			8 (2 x 4)			12 (3 x 4)		15,2 (4 x 3,8)			
		START-UP CHARACTERISTICS (EXCLUDING PUMP FOR HYDRAULIC MODELS)													
Max. nominal current in A	* 230 V	229,2	344,7	267,9	383,4	399,2	425,2	441	456,8	476,1	514,7	565,6	-	-	-
	400 V	134,1	194,6	156	216,5	225,9	240,1	249,5	258,9	269,3	292,1	321,3	380	410	430

AQUACIAT		100	150	200	250	300	350	400	450	500	600	750	753	900	1000
		ANTI-FROST PROTECTION LD - LDC - ILD													
Power	W	100				3 x 100				(I)LD : 1200 (I)LDC : 1300					
Max. nominal current in A	1 ph. 230 V	0,45				0,9				-					
	TRI 400 V	-				-				(I)LD : 1,73 (I)LDC : 1,88					
		ANTI-FROST PROTECTION + HYDRAULIC CIRCUIT LDH - ILDH													
Power	W	1500 (3 x 500)				2800									
Max. nominal current in A	* 230 V	6,9 (3 x 2,3)													
	400 V	6,9 (3 x 2,3)				4,04									

SINGLE pump ** (versions LDH - LDC - ILDH)		N°	40	41	42	43	117	118	119
230* / 400 V 3 ph - 50 Hz + earth	Power	kW	0,75	1,1	1,5	1,85	2,2	4	7,5
	Max. nominal current in A	* 230 V	3,22	4,64	5,9	8,02	-	-	-
		400 V	1,85	2,67	3,9	4,61	4,5	7,8	13,8

** Models 100 to 300 are equipped, in the standard version, with the pumps mentioned in the table.

DOUBLE pump ** (versions LDH - LDC - ILDH)		N°	217	218	219
230* / 400 V 3 ph - 50 Hz + earth	Power	kW	2,2	4	7,5
	Max. nominal current in A	* 230 V	-	-	-
		400 V	4,5	7,8	13,8

* 230 V - 3 ph : Controlled voltage in France

Total intensity of unit : sum of the max. nominal intensities mentioned in the above tables.

SOUND LEVELS

The AQUACIAT LD(C / H) and ILD (H) range is strictly designed to combine the "noiseless" assembly techniques for attenuation of vibrations and sound sources.

- SCROLL compressor(s) located outside the air flow ①.
- Anti-vibration mounting of several compressors on a structure isolated from the frame ②.
- Pipework independent from the unit structure.
- Low speed fans (500 rpm) LOW NOISE ③.
- Antivibratil mounts supplied as standard Æ ④.

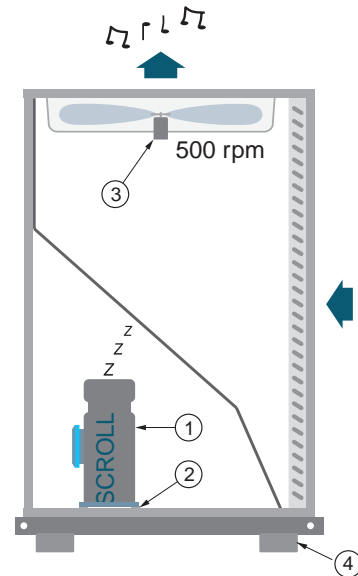

PROPELLER
CONDENSER

- Acoustic pressure levels ref 2×10^{-5} Pa ± 3 dB

Measurement conditions :

- Compressor(s) + fan(s) at low speed (500 rpm) LOW NOISE
- Free field
- 10 m distance from the unit, 1.50 m from the ground
- Directivity 2

AQUACIAT	PRESSURE LEVEL SPECTRUM (dB)							Total level dB(A)
	63 Hz	125 Hz	250 Hz	500 Hz	1000 Hz	2000 Hz	4000 Hz	
100	63	54	47	47	43	40	34	48
150	60	57	48	46	46	40	40	50
200	66	57	50	50	46	43	37	51
250	60	53	51	49	45	40	39	50
300	61	55	53	49	46	41	39	51
350 - 400 - 450 - 500	67	60	55	52	48	43	37	54
600 - 750	62	61	57	55	50	46	40	56
753	-	54.5	54.5	56.1	52.5	48.7	44.6	57.5
900 - 1000	-	55.7	55.7	57.3	53.8	50	45.9	58.8

NOTE : we remind that the acoustic pressure level is given as an indication and that only the sound power level is comparable and certified.

Following ISO 3744 Norm $L_p = L_w - 10 \log S$

- Acoustic power levels ref 2×10^{-12} W ± 3 dB

Measurement conditions :

- Compressor(s) + fan(s) at low speed (500 rpm) LOW NOISE

AQUACIAT	POWER LEVEL SPECTRUM (dB)							Total level dB(A)
	63 Hz	125 Hz	250 Hz	500 Hz	1000 Hz	2000 Hz	4000 Hz	
100	91	82	75	75	71	68	62	76
150	88	85	76	74	74	68	68	78
200	94	85	78	78	74	71	65	79
250	88	81	79	77	73	68	67	78
300	89	83	81	77	74	69	67	79
350 - 400 - 450 - 500	96	89	84	81	77	72	66	83
600 - 750	91	90	86	84	79	75	69	85
753	-	83.5	83.4	85.1	81.5	77.7	73.6	86.5
900 - 1000	-	84.7	84.7	86.3	82.8	79	74.9	87.8

VERSION WITH HYDRAULIC KIT

AQUACIAT the all-in solution

The PLUG & COOL solution with AQUACIAT

The AQUACIAT hydraulic pack integrates in all the components of the hydraulic circuit required for a normal operation of the circuit.

PROPELLER
CONDENSER

AQUACIAT	ILDH	LDH	LDC
Buffer tank	●	●	-
Expansion vessel	●	●	●
Water flow controller	●	●	●
Pressure gauge with isolating valve	●	●	●
Anti-frost protection of the whole circuit	●	●	●
Drain circuit	●	●	●
Manual and automatic purge	●	●	●

AQUACIAT	ILDH	LDH	LDC
Safety valve	●	●	●
Filling hole with valves	100 - 750	100 - 750	100 - 600
Large choice of single or double pumps	●	●	●
Adjusting valve	100 - 750	100 - 750	100 - 600
Water filter	●	●	●
Regulation of the assembly	●	●	●

The AQUACIAT installation is very easy, this unit being equipped with an hydraulic pack whose components are selected in an optimal way, mounted and tested in factory, The design of components, supplies, connections is no longer necessary..

Delivered fully equipped, the AQUACIAT is ready to operate.

In short, the AQUACIAT hydraulic pack optimizes the preparation and operation time and the required.space.

Connecting, cooling ... ; with AQUACIAT everything becomes simple and economical.

HYDRAULIC DIAGRAM ILDH 200 - 600, LDH 100 - 750, (I) LD (H / C) 753 -1000

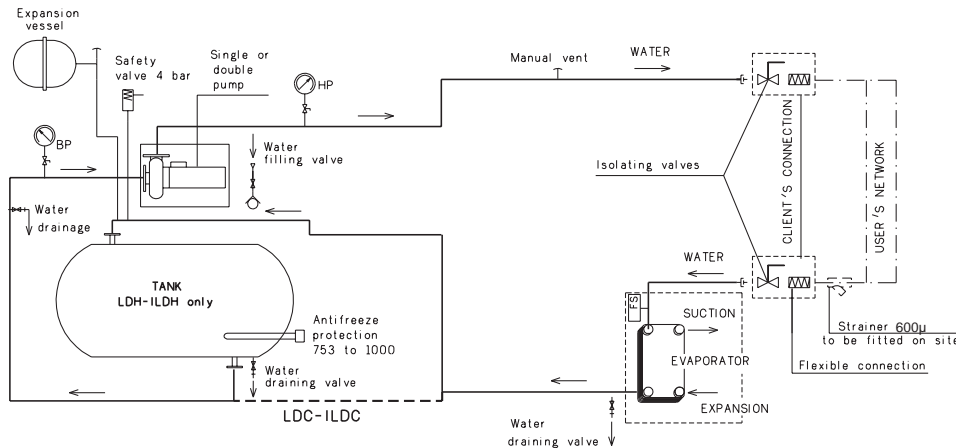

HYDRAULIC DIAGRAM LDC 100 - 600

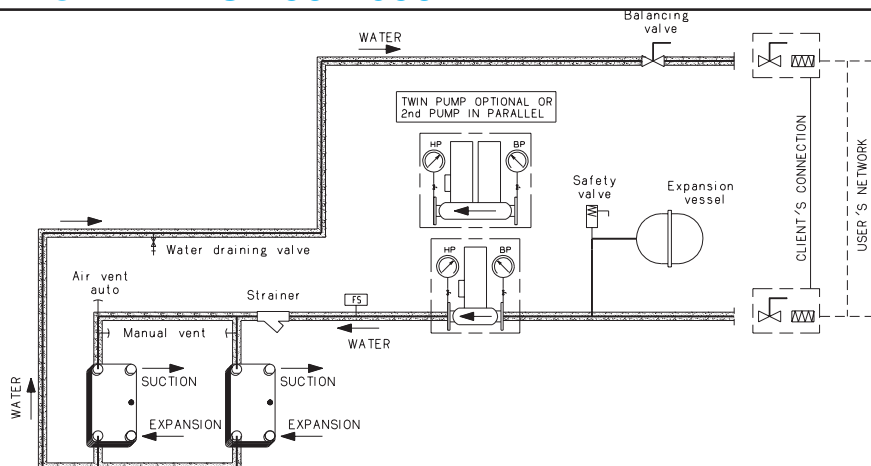

DIMENSIONS

AQUACIAT 100 to 300 LDH - ILDH

PROPELLER
CONDENSER

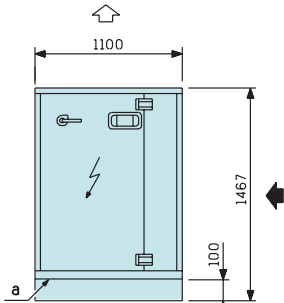

Fig.1

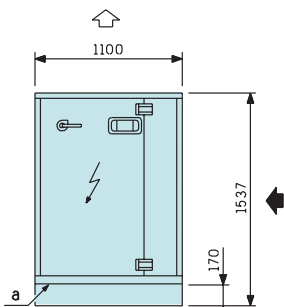
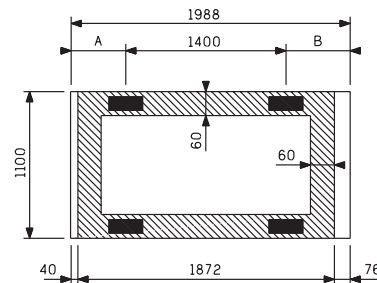
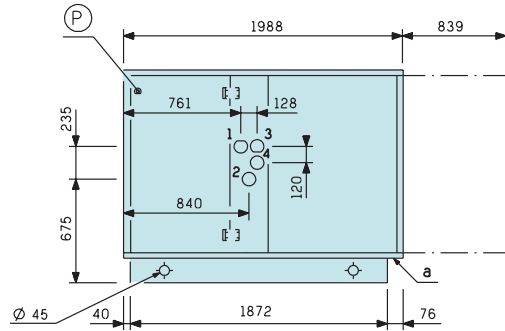
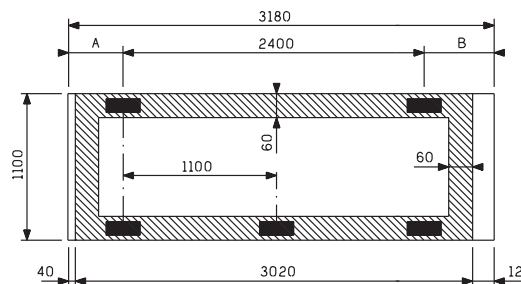
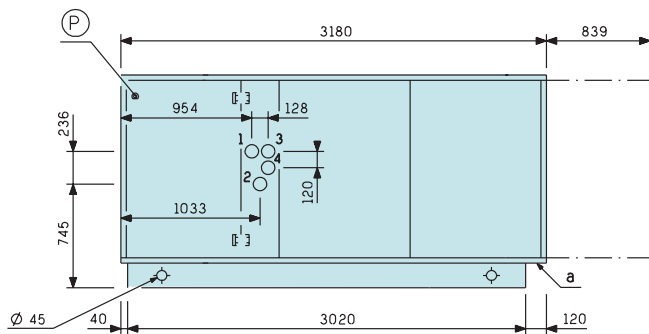

Fig.2



External air inlet

External air discharge

1-Water outlet 2-Desuperheater outlet

2-Water inlet 2-Desuperheater inlet

a Electrical supply \varnothing 45mm: 100-150
 \varnothing 60mm: 200-250-300

Anti-vibration mounts optional

A clear space of 1 m on all sides for the units should be allowed for servicing and maintenance operations.

AQUACIAT Series	100	150	200	250	300	200	250	300	
			LDH			ILDH			
FIG.	1	1	2	2	2	2	2	2	
1 = \varnothing G	1" 1/4	1" 1/4	2"	2"	2"	2"	2"	2"	
2 = \varnothing G	1" 1/4	1" 1/4	2"	2"	2"	2"	2"	2"	
3 = \varnothing G	3/4"	3/4"	1" 1/2	1" 1/2	1" 1/2	1" 1/2	1" 1/2	1" 1/2	
4 = \varnothing G	3/4"	3/4"	1" 1/2	1" 1/2	1" 1/2	1" 1/2	1" 1/2	1" 1/2	
A	253	283	255	270	290	315	330	345	
B	335	305	525	510	490	465	450	435	
Mass in kg	In service	830	865	1400	1445	1485	1470	1510	1550
	empty	655	690	1080	1125	1165	1150	1190	1230

DIMENSIONS

AQUACIAT (I)LD - (I)LDH - (I)LDC 753 - 900 - 1000

PROPELLER
CONDENSER

Top view
(I)LD - (I)LDH - (I)LDC
N° 753 - 900 - 1000

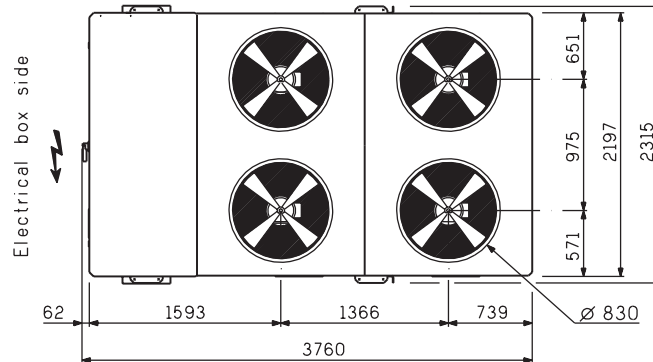

GROUND FIXATION OF FRAME

AQUACIAT LD - LDC - LDH - ILD - ILDH

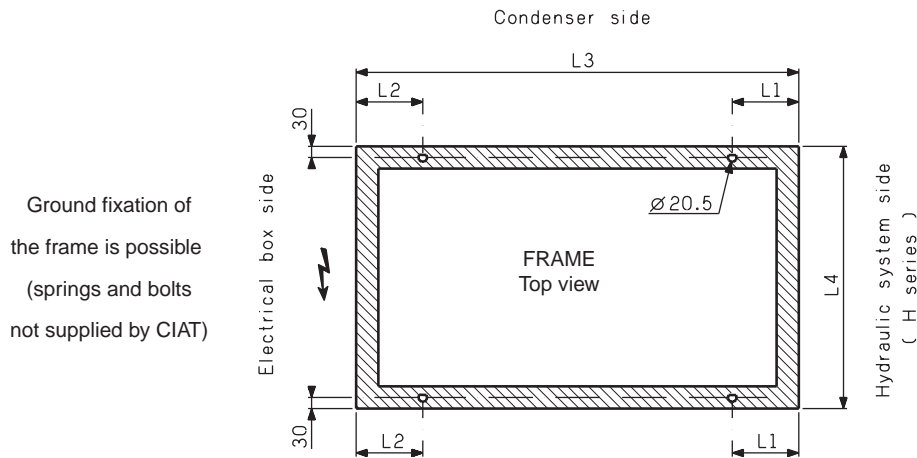

AQUACIAT	LD - LDC				LDH				ILD				ILDH			
	L1	L2	L3	L4	L1	L2	L3	L4	L1	L2	L3	L4	L1	L2	L3	L4
100 - 150	150	150	1256	1100	180	180	1872	1100								
200 - 250 - 300	180	180	2186	1100	180	300	3020	1100	180	180	2186	1100	180	300	3020	1100
350	489	360	2244	1300	549	610	3289	1300	489	360	2244	1300	549	610	3289	1300
400	489	360	2244	1300	549	610	3289	1300	489	510	2694	1300	529	510	3789	1300
450	489	510	2694	1300	529	510	3789	1300	489	510	2694	1300	529	510	3789	1300
500	489	510	2694	1300	529	510	3789	1300	580	640	3295	1300	582.5	640	4340	1300
600	580	640	3295	1300	582.5	640	4340	1300	580	640	3295	1300	582.5	640	4340	1300
750	580	640	3295	1300	582.5	640	4340	1300								
753 - 900 - 1000	986.5	985.5	3684	2185	986.5	985.5	3684	2185	986.5	985.5	3684	2185	986.5	985.5	3684	2185

RÉGULATION CONNECT



ERGONOMIC INTERFACE PANEL

- LCD multilingual screen (2 lines of 20 characters)
- Pressures and temperatures reading
- Pump control
- Communication

Available free contacts inputs / outputs

- Inputs :*
- External ON/OFF contact
 - Setpoint 1/2 selection
 - Cooling / heating selection
 - Compressors load shedding

- Outputs :*
- General fault of the unit

RS 485 OUTPUT IN STANDARD

MODBUS-JBUS open Protocol

FREE CONTACTS RELAY CARD (OPTION)

- Available outputs :*
- Water flow fault
 - Antifreeze fault
 - Pump fault
 - Fans fault
 - Low and high pressure fault
 - Compressors safety fault
 - Discharge temperature fault
 - Compressors running status

REMOTE CONTROL BOX (OPTION)

Identical to the ergonomic interface

PROPELLER
CONDENSER